

**SOPORTE PARA CARRIL HORIZONTAL**  
HORIZONTAL CHANNEL SUPPORT

**FICHA TÉCNICA**  
TECHNICAL DATA SHEET

Formada por dos piezas de acero cincado, fabricadas por estampación y posteriormente unidas el ángulo de 90° por medio de soldadura de cordón. Esta pieza se utiliza para la unión de dos guías en ángulo recto.

*Made up of two pieces of galvanized steel, manufactured by stamping and later joined at an angle of 90° by means of seam welding.  
This piece is used to join two guides at right angles.*



**DATOS TÉCNICOS / TECHNICAL DATA**

CÓDIGO Code	MEDIDA Measure AxB m.m.	CARRIL Channel m.m.
SCH0816	<b>8x16</b>	27x18 / 28x30
SCH1016	<b>10x16</b>	38x40 / 40x20

Cod.: **SCH0816**

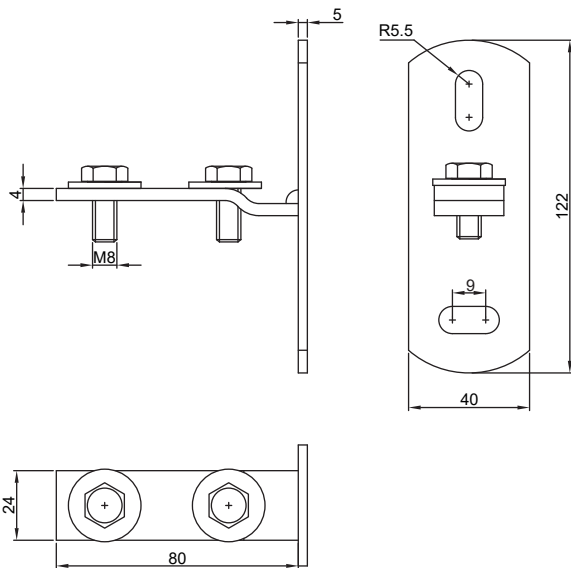

Cod.: **SCH1016**

